

# Sound Weaves

BY LONNI ROSSI



Sound Weaves quilt  
designed by: **Lonni Rossi**

Quilt Size: **58" x58"**

[andoverfabrics.com](http://andoverfabrics.com)



## About Sound Weaves

Hand-drawn lines play against a flat color ground to simulate weaving. Mechanical lines and spaces create the exotic beat of sound waves. Half-circles in half-square triangles evoke light and color reflections on the water.

Playing off the desire to say “sound waves” the three color groups were chosen to evoke the China Sea (green/red/black), the Mediterranean Sea (blue/yellow/white) and the romantic Caribbean. (turquoise and lime citrus). — *Lonni Rossi*

andover



makower uk  
*The Henley Studio*

Free Pattern Download Available

1384 Broadway New York, NY 10018  
Tel. (800) 223-5678 • [andoverfabrics.com](http://andoverfabrics.com)

# Sound Weaves Quilt



Introducing Andover Fabrics new collection: **SOUND WEAVES** by Lonni Rossi

Quilt designed by Lonni Rossi

Quilt finishes 58" x 58"  
16 Blocks: 8½" x 8½"  
32 Border Blocks: 4" x 4"

*What a visual impact this quilt makes. The modern look is executed here in quilt design, fabric, and color palette. The blocks are easier to make than they appear. The quilt is a good size to grace a dorm room or the wall of a family room.*

## Cutting Directions

**Note:** Read assembly directions before cutting patches. All measurements are cut sizes and include ¼" seam allowances. Borders are cut the exact lengths required plus ¼" seam allowances. WOF designates the width of fabric from selvedge to selvedge (approximately 42" wide).

**Fabric A** Fussy-cut (32) squares 3⅜" x 3⅜" (read Step 4)

**Fabric B** Cut (3) strips 3" x WOF for blocks  
Cut (8) strips 1¾" x WOF for blocks

**Fabric C** Cut (2) borders 2½" x 58½", cut crosswise and pieced  
Cut (2) borders 2½" x 54½", cut crosswise and pieced

**Fabric D** Cut (4) strips 1¾" x WOF for blocks  
Cut (16) strips 1¼" x WOF for blocks

**Fabric E** Cut (2) borders 5½" x 54½", cut crosswise and pieced  
Cut (2) borders 5½" x 44½", cut crosswise and pieced  
Cut (6) strips 1¾" x WOF for blocks  
Cut (32) sashes 1½" x 4½"  
Cut (64) squares 3" x 3", cut in half diagonally to make 64 half-square triangles (cut slightly larger to be trimmed)

**Fabric F** Cut (2) strips 1¾" x WOF for blocks

**Fabric G** Cut (2) borders 1½" x 36½", cut crosswise  
Cut (2) borders 1½" x 34½", cut crosswise

**Fabric H** Cut (2) strips 2¼" x WOF for blocks  
Cut (6) strips 1¼" x WOF for blocks

**Backing** Cut (2) panels 33" x 66", pieced to fit quilt top with overlap on all sides  
For *invisible* binding:  
Cut (2) strips 3½" x width of quilt raw edge to raw edge  
Cut (2) strips 3½" x length of quilt raw edge to raw edge

**Binding (opt.)** For *traditional* binding: (from fabric of your choice)  
Cut (7) strips 2½" x WOF

## Fabric Requirements

		Yardage	Fabric
<b>Fabric A</b>	border blocks	1½ yards	7882-R
<b>Fabric B</b>	blocks	¾ yard	7883-R
<b>Fabric C</b>	outer border	½ yard	7884-RK
<b>Fabric D</b>	blocks	1 yard	7884-TG
<b>Fabric E</b>	blocks, border	2 yards	5468-DK
<b>Fabric F</b>	blocks	⅛ yard	5468-LN
<b>Fabric G</b>	inner border	¼ yard	5468-O
<b>Fabric H</b>	blocks	½ yard	5468-Y
<b>*Backing</b>		4½ yards	7882-R

\*includes invisible binding strips

# Sound Weaves Quilt

## Making the Quilt

1. Referring to the block strip piecing diagram, cut the appropriate WOF strips the required lengths. Stitch strips end to end where needed. Matching centers, join the strips side by side in the order shown. Press the seam allowances in one direction. To trim this pieced unit to 9" square, position a large square acrylic ruler so the diagonal line on the ruler is aligned with the center seam of the pieced strips as shown. Cut along two edges of the ruler. Realign the ruler so the 9" markings match the trimmed sides. Trim the other two sides. Be sure the square measures 9" from edge to edge. Hint: It is important that the ruler's diagonal is aligned with the center seam every time. However, it doesn't matter exactly where the ruler is placed on the pieced strips as long as every block is cut the same.

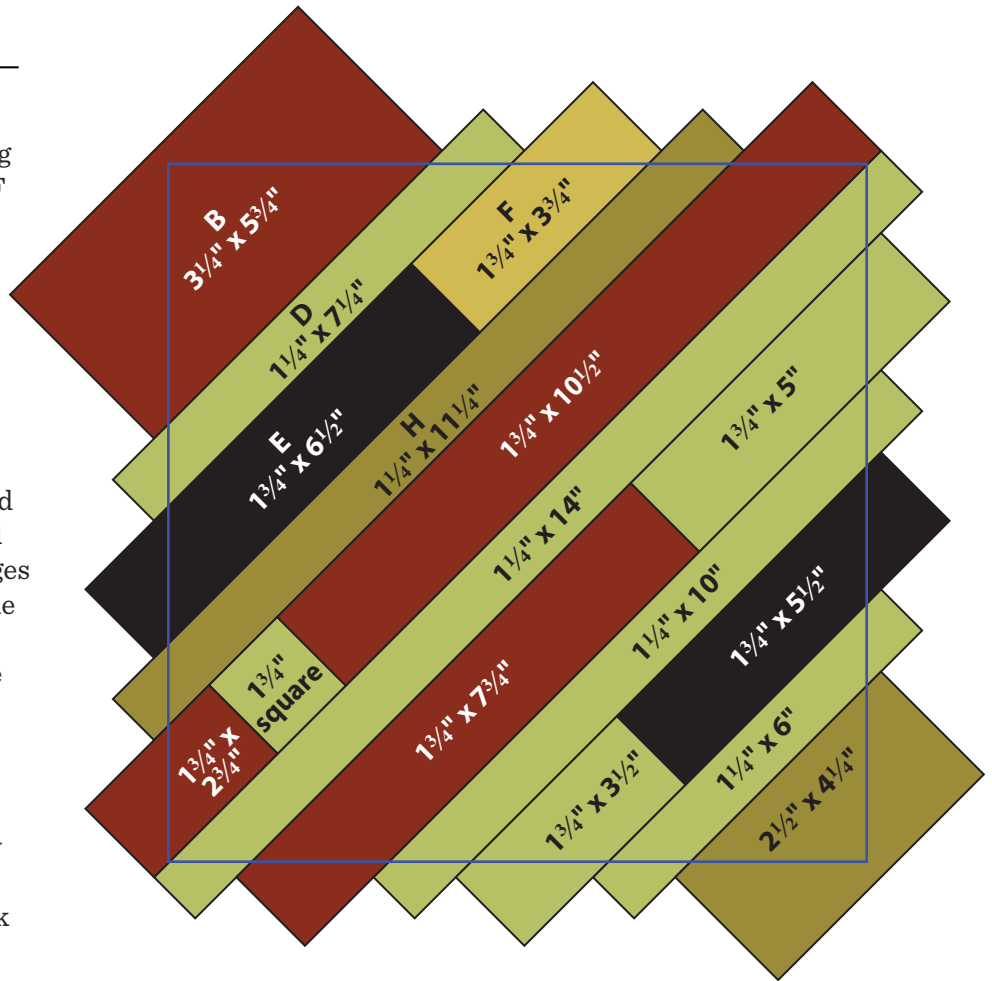

Repeat the process to make 16 blocks. Handle the bias edges carefully. You may want to sew a line of stay-stitches close to the edge to stabilize the blocks.

2. Referring to the Quilt Diagram, join 4 blocks to make a larger unit, turning the blocks as shown. Make 4. Join the large units in 2 rows of 2. Join the rows.
3. Sew the shorter Fabric G borders to the sides of the quilt. Sew longer borders to the top and bottom.
4. Note that the Fabric A centers of the border blocks are made with just the red and gray printed circles. Carefully fussy-cut the red/gray on-point squares, leaving a 1/4" seam allowance all around each square. Referring to the border block diagram, sew a Fabric E half-square triangle to each side of a Fabric A square. Press seam allowances away from the center. Trim the blocks to 4 1/2" x 4 1/2" if necessary, leaving an even seam allowance all around. Make 32 border blocks.
5. Join 7 border blocks and 8 Fabric E sashes to make a pieced border. Make 4 borders like this. Sew borders to opposite sides of the quilt. Sew a border block to each end of remaining pieced borders. Sew to the top and bottom.
6. Sew the shorter Fabric E borders to the sides of the quilt. Sew longer borders to the top and bottom. Repeat with the Fabric C borders.

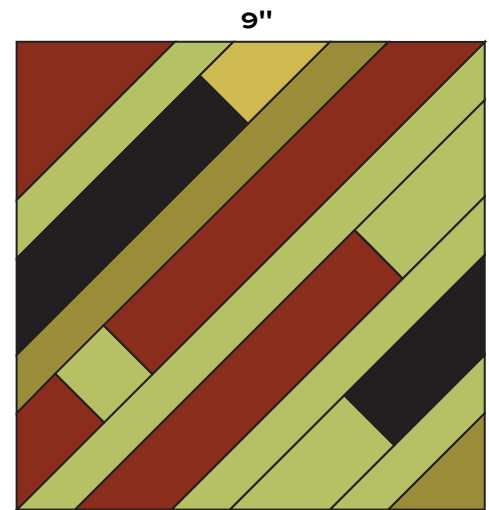

Block – Make 16

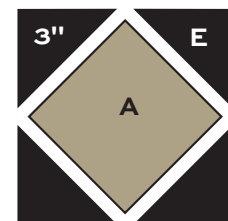

Border Block – Make 32

# Sound Weaves Quilt

## Finishing the Quilt

7. Layer the quilt with batting and backing and baste. Quilt in the ditch around borders, sashes, and the strips in the big blocks. Quilt around the printed motifs in the border blocks.
8. Follow the directions for Lonni's invisible binding. If you prefer traditional binding, do not cut the 3½"-wide strips listed for the backing fabric, but cut strips 2½" x WOF from the fabric of your choice. Bind the quilt to finish.



Quilt Diagram

# Sound Weaves Quilt

## Invisible Binding

These directions are for binding that doesn't show on the front of the quilt. Strips of fabric are stitched around the quilt to make a facing with mitered corners. The entire facing is turned to the back of the quilt. These directions work for any quilt when you want the design to be uninterrupted all the way to the edge of the quilt.

### Step 1

When you have finished quilting, trim the edges of the quilt so all sides are straight and the corners are square.

### Step 2

Measure through the center of your quilt from the top raw edge to the bottom raw edge. Note this measurement. It will be the length of your side strips. Similarly, measure from side to side across the center of the quilt. This will be the length of your top and bottom strips. Cut the number of 3½"-wide strips needed to construct the facing strips. Piece them with diagonal seams as necessary to make 2 side strips and 2 top/bottom strips the exact length needed for your quilt.

### Step 3

Press ½" to the wrong side on one long edge of each strip.

### Step 4

Lay quilt face up on a table. Right sides together, align the unpressed edge of one strip with the corresponding edge of the quilt top, matching centers. Starting at the center, pin the binding to the quilt to within 6 inches of each corner. Continue in this manner until you have pinned the binding strips to all four edges of the quilt top.

### Step 5

Using a 45° triangle ruler, mark the sewing line for the miter at the end of each strip, remembering to add the seam allowance. With right sides together, pin corners and sew the miters without removing the pinned binding from the quilt. Trim off the excess fabric, leaving a ¼" seam allowance.

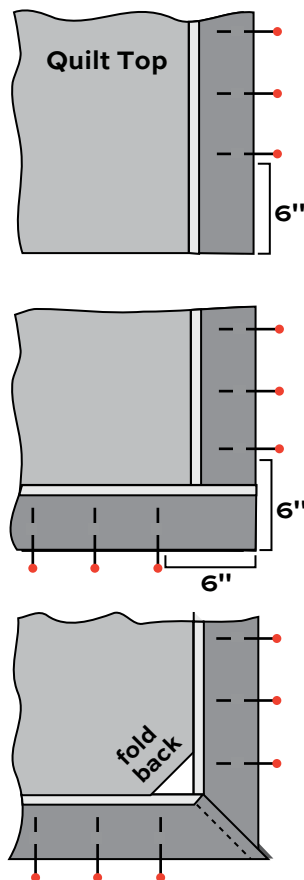

### Step 6

Finger press the seam allowances open and finish pinning the corners to the quilt. Using a walking foot, sew the binding to the quilt using a ⅜" seam all the way around all four sides. Trim the seam allowances at the corners.

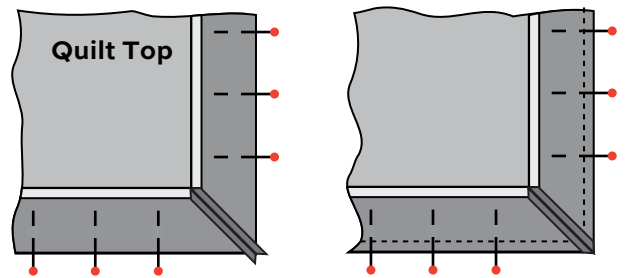

### Step 7

Turn the binding to the back of the quilt, making sure the corners are fully turned to a nice crisp point.

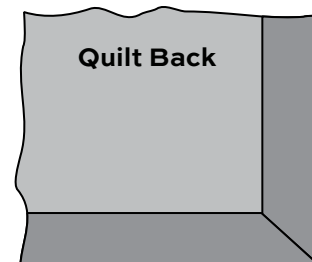

### Step 8

Steam press so the edge is straight and the quilt lies flat. Whip stitch the folded edge to back of quilt by hand, being careful not to let any stitches show through to the front of the quilt.

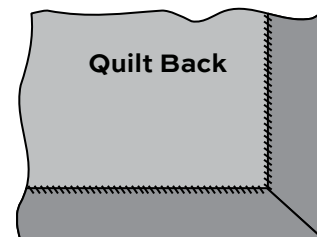

# Sound Weaves

BY LONNI ROSSI



7882-O



7882-R\*

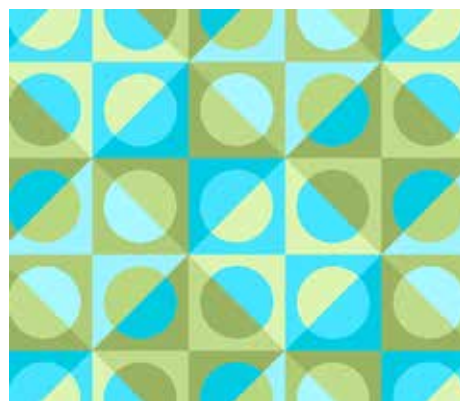

7882-T



7883-O

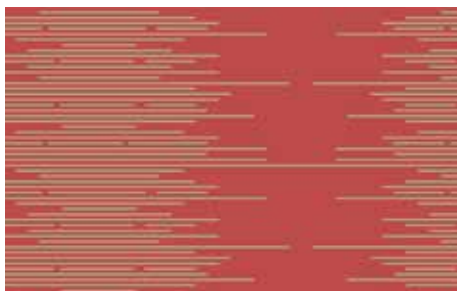

7883-R\*



7883-T



7884-OB



7884-RK\*



7884-TG\*



5468-B



5468-C1



5468-DK\*



5468-LN\*



5468-LT3



5468-O\*



5468-Y\*



5468-Y3

\*Indicates fabrics used in quilt pattern. Fabrics shown are 25% of actual size.

andover

•  
•  
•  
•  
•  
makower uk  
*The Henley Studio*

Free Pattern Download Available

1384 Broadway New York, NY 10018  
Tel. (800) 223-5678 • andoverfabrics.com